

The Man Who Rode Whirlwinds

A Son's Story of the Amazing Hal Hermes

Richard H. Hermes

The Man Who Rode Whirlwinds

A Son's Story of the Amazing Hal Hermes

By Richard H. Hermes

This is the true tale of a 19-year-old Oklahoma schoolboy who became a courageous Wright Field test pilot during WW2. During his 30-year career as a test pilot, Hal Hermes was one of the best and he flew with many of the pioneers and legends of aviation history. His collection of photographs and papers reveal a lifetime of personal drive and achievement.



Cover photograph: Andreas Feininger's time-lapse photo of a Sikorsky S-51 helicopter taking off at night circa 1949 (*Life Magazine*). Hal Hermes had a direct role in the certification of the Sikorsky S-51 while working at the CAA.



This book is dedicated to
Lila Hermes Selman

June 8, 2015
Happy Birthday Mother

Many thanks to **Sylvia Koreen** for her help with this book. I am grateful for a lifetime of love and encouragement from my sisters, Nancy and Diana.



The Man Who Rode Whirlwinds

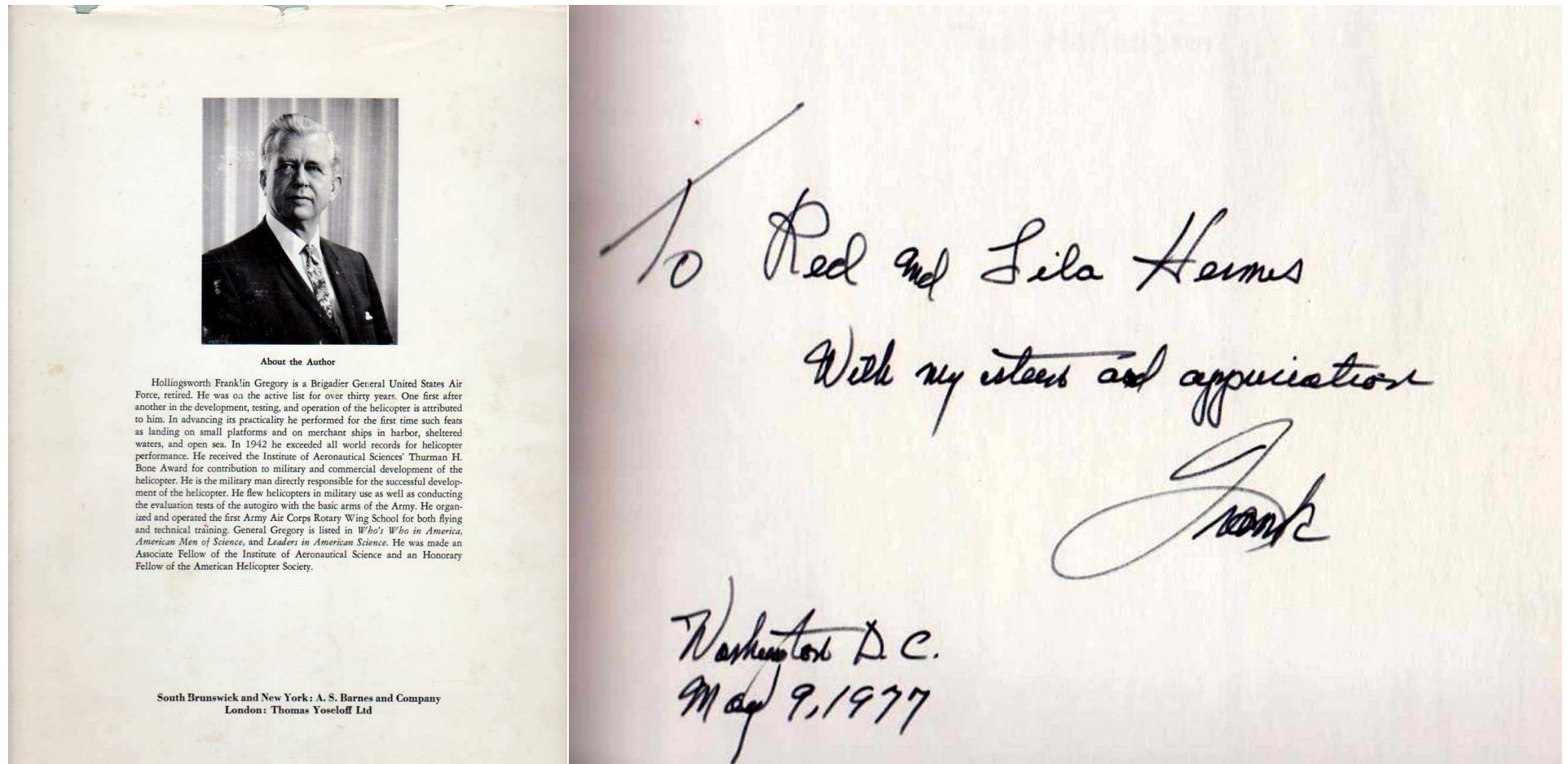

This personal inscription is from Frank Gregory to Hal and Lila Hermes in a copy of his book, *The Helicopter -- A Pictorial History*. The back cover reads:

Hollingsworth Franklin Gregory is a Brigadier General United States Air Force, retired. He was on the active list for over thirty years. One first after another in the development, testing, and operation of the helicopter is attributed to him. In advancing its practicality, he performed for the first time such feats as landing on small platforms and on merchant ships in harbor, shelter waters and in open sea. In 1942, he exceeded all world records for helicopter performance. He received the Institute of Aeronautical Sciences' Thurman H. Bone Award for contributing to military and commercial development of the helicopter. He is the military man directly responsible for the successful development of the helicopters. He flew helicopters in military use as well as conduction the evaluation test of the autogiro with the basic arms of the Army. He organized and operated the first Army Air Corps Rotary Wing School for both flying and technical training. General Gregory is listed in *Who's Who in America*, *American Men of Science*, and *Leaders in American Science*. He was made an Associate Fellow of the Institute of Aeronautical Science and an Honorary Fellow of the American Helicopter Society.

© Richard H. Hermes 2015. The book author retains sole copyright to his contributions to this book.



The Blurb-provided layout designs and graphic elements are copyright Blurb Inc. This book was created using the Blurb creative publishing service. The book author retains sole copyright to his or her contributions to this book.

"The Man Who Rode Whirlwinds" is listed in WorldCat, the OCLC's World Catalog database, the world's largest library catalog.

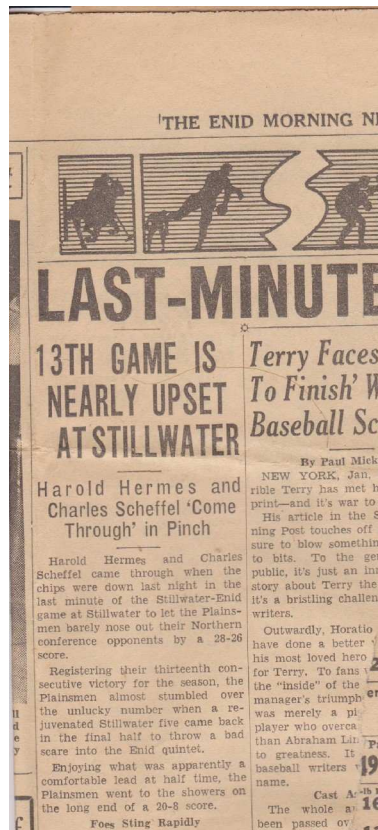

December 2, 1939

In late 1939, war was raging.

Britain had declared war on Germany; U-boats were attacking convoys in the Atlantic; Japan pressed its invasion of China; and Helsinki was bombed on November 30th as Russia began their invasion of Finland.

The United States was still officially neutral, yet on December 2, 1939, Hermes joined the Oklahoma National Guard after his second year of mechanical engineering studies at the University of Oklahoma.

Hal Hermes was born on February 11, 1920 in Independence, Kansas.

He attended Enid High School in Enid, Oklahoma where he was on the varsity football and basketball teams in his junior and senior years.

As a senior in 1938, Hermes was a 6'1" forward on the basketball team (winning 28 out of 30 games). He was a guard on the "Enid Eleven" football team, which went undefeated that year.

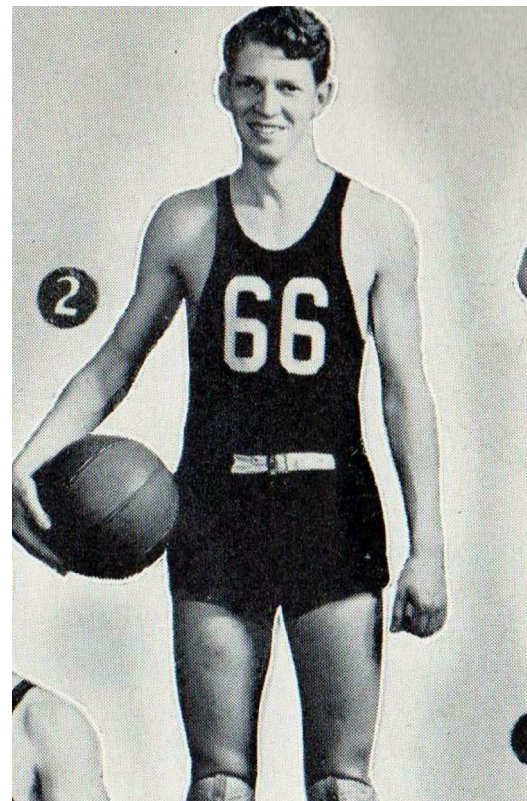

The Man Who Rode Whirlwinds



On left, Staff Sergeant Harold H. Hermes at his graduation from Advanced Communications School on January 3, 1941 at Camp Barkley, Texas.

This photo was taken before Hal was accepted as an Air Cadet and eleven months before the Japanese attack on Pearl Harbor on December 7, 1941.

On March 17, 1942, Harold typed a letter to his mother from Camp Barkley, Texas:

"This camp is certainly terrible because of the dust and wind that is always blowing. The dust just keeps sifting in on the floors, beds, and clothing all the time. I have taken a few pictures of the place while we were putting up the tents...we had to take a shower in cold water. We are still eating out of mess kits."



Harold's mother received a letter dated May 26, 1942 that said,



"... your son...has been selected for training as a Pilot in the Army Air Force. In order to win this war it is vital to have the best-qualified young men at the control of our military aircraft."

This small photo was in the local newspaper.

Wilbur Wright Field before WW2



After completing basic training and advanced communications training, Hermes was assigned to the Army Air Forces where he advanced through all levels of flight training.

Hermes also proved his leadership abilities. As a cadet in Primary Flying School, he was put in charge of 200 aviation cadets. In Basic Flying School, Hermes was assigned the duties of Cadet Colonel in charge of approximately 600 cadets.

Upon his graduation from the Army Air Forces Advanced Flying School at Ellington Field, Texas (Class 43-A), Hermes was promoted to 2nd Lieutenant in January 1943.

He was then assigned to Air Technical Services Command at Wright Field in Dayton, Ohio where, after completing several specialized courses in Performance Flight Testing, he began duties as a test pilot for all types of military aircraft.



Wind tunnel complex at Wright Field.

Wright Field was, and still is, the center of aviation research, design and testing for all military aircraft.

Now known as **Wright-Patterson Air Force Base**, it began in 1903 by the Wright Brothers. After their successful proof-of-concept flights at Kitty Hawk, North Carolina, they purchased an 84-acre plot of land near their home in Dayton, Ohio, to serve as their experimental flying field, as they sought to transform their invention into a practical flying machine.

World War II profoundly altered both Wright and Patterson Fields. From a population of 3,700 in 1939, the workforce at the two fields would eventually peak at over 50,000. The workload shifted from a 40-hour week to round-the-clock operations. Massive construction programs erected new research centers and housing complexes to accommodate wartime operations.

This is where legendary "Wright Stuff" pilots come from.

The Man Who Rode Whirlwinds

After six months at Wright Field, Hermes was ordered to go to the Sikorsky Factory in Bridgeport, Connecticut for helicopter training from June 7 through July 2, 1943. On June 16th, Hermes soloed "for an hour" - the 17th US pilot to do so. He flew a Sikorsky R-4, which had three rotor blades that were nothing more than metal tubing covered by fabric.

On July 2, before returning to Wright Field, Col. Gregory informed Hermes and Peterson that they "would be doing some landings on a transport ship."



The Army Air Forces' first class of helicopter pilots at the Sikorsky Factory (June 7 - July 2, 1943).

Igor Sikorsky is in the middle in the dark suit. On his left is **Col. Frank Gregory** (Army Air Forces, in charge of all helicopter projects); **C. L. "Les" Morris** (chief test pilot Sikorsky Aircraft); **Lt. Frank W. Peterson** (Hermes' best friend); Lt. Col. Leslie B. Cooper); **Lt. Harold Hermes** (Army Air Forces).

On July 3, 1943, Hal Hermes and Frank Peterson helped install floats on an R-4 and practiced landing in a 20-foot square laid out on the grass. On July 6th, two R-4's (one with floats the other with regular landing gears), were flown onto the transport ship, USAT *James Parker*.

Over the next three days Hermes and Peterson, both having soloed in a helicopter only three weeks earlier, helped make, "aeronautical history" (quote from *The Helicopter: A Pictorial History*). Never before had a helicopter been operated on a ship in open seas. On board observers included the top American and British war brass representing Army, Army Air, Navy and Coast Guard branches.



Lt. Harold "Red" Hermes landing a Sikorsky R-4 on the USAT *James Parker* on July 7-9, 1943.

This photograph is inscribed on the back; "Frank, This is H. H. Hermes, Pete" believed to be a memo to Lt. Col Frank Gregory from Frank W. Peterson (called "Pete" by his friends). A total of "162 landings and takeoffs (20 hours of flying time) were made in winds ranging from 5 to 25 knots while the ship pitched up to 6 1/2 degrees."

The Man Who Rode Whirlwinds

Among the many notable observers onboard the USAT *James Parker* was Col. Edwin E. Aldrin, Sr.

Many know him as the father of Buzz Aldrin, Jr., former astronaut and the second person to walk on the Moon, but Aldrin, Sr. was a distinguished aviator in his own right. For example, he made the first transatlantic dirigible round-trip flight in the *Hindenburg*. Interestingly, Aldrin, Sr. was in the first class of the Air Services Engineering School (now known as the Air Force Institute of Technology), where his son, Buzz Aldrin, Jr., would also graduate many years later.

Sometime around the *James Parker* landings, *Hermes* gave a helicopter demonstration ride to Aldrin, Sr.



In late 1943, Hermes had the opportunity to meet Frank T. Coffyn who was a member of the original Wright Brothers Demonstration Team and had been flying since 1910. At the time, Coffyn was representing Liquidometer Corp's interest in supplying control gauges for the helicopter. Hermes gave Coffyn his first helicopter ride and Coffyn became very determined to obtain a helicopter pilots license.

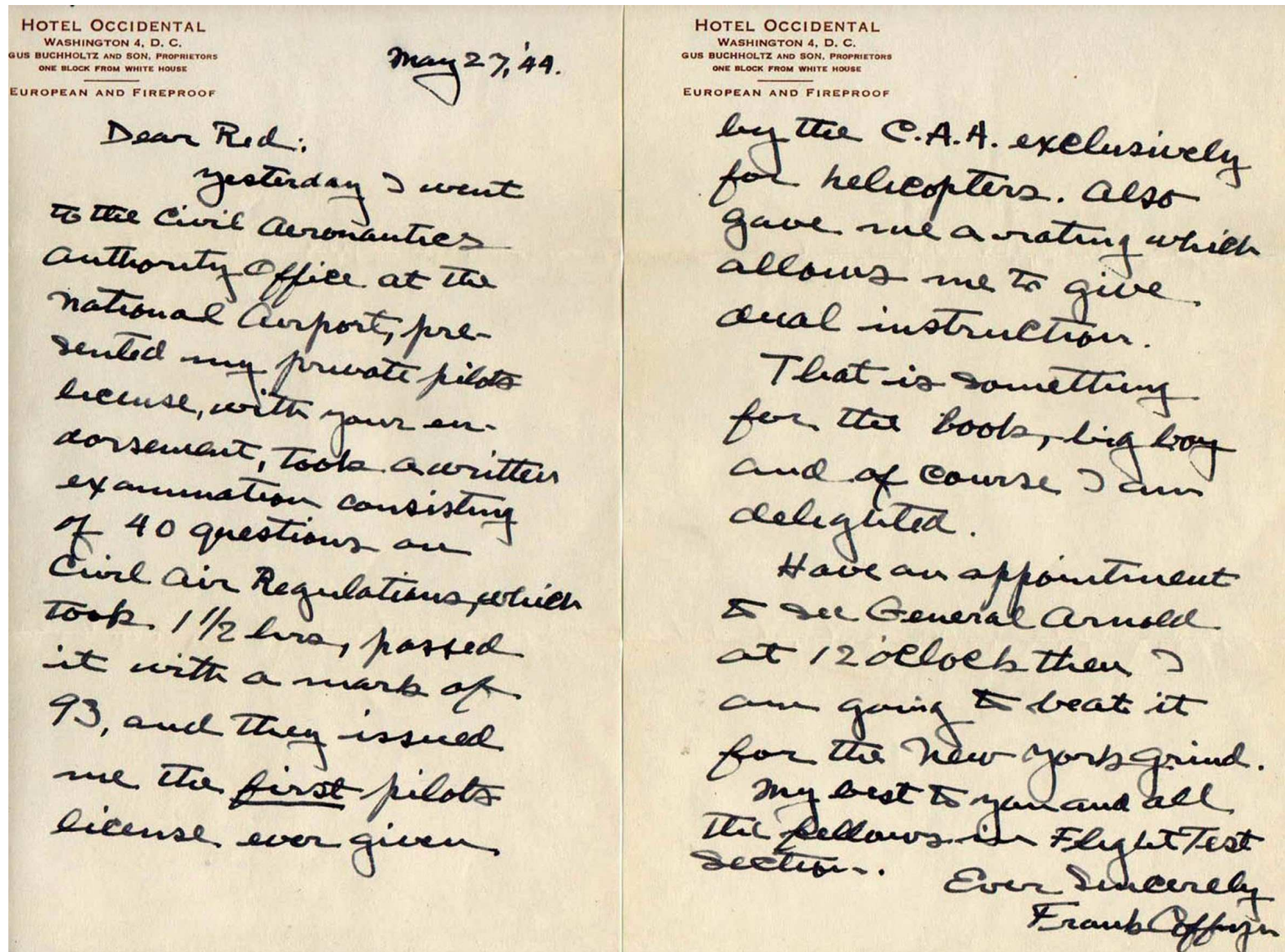

Coffyn was a civilian, but there were no civilian helicopter instructors because the Civil Aeronautics Administration (CAA) had not yet established a helicopter pilots rating system. Coffyn would not give up: he met with Les Morris (Sikorsky's chief test pilot) and Col. Frank Gregory (head of USAAF's helicopter program) and eventually obtained the permission to be trained by the Army Air Forces granted by General Henry "Hap" Arnold, who was Chief of Army Air Forces. This "unusual permission" (as it was called then) was given because Coffyn and Arnold were longtime aviators. They shared equally long flying careers: Coffyn held F.A.I. pilot's license #26 and Arnold held #29 and their instructor was Orville Wright.

Between April 26 and May 12, 1944, 66-year old Coffyn received six hours of instruction from Hermes (with "129 landings"). After he received his helicopter's license, he wrote the above letter to Hal "Red" Hermes.

HILLER HELICOPTER-NEWS

Published Monthly by the Manufacturers of Hiller Helicopters



Vol. 4 No. 3

PALO ALTO, CALIFORNIA

March, 1953

COMMERCIAL SALES RESUMED WITH 12-B

FRANK T. COFFYN IS STAR ON "THIS IS YOUR LIFE" NATIONAL TV PROGRAM



Lured to Los Angeles on a business pretext, Frank T. Coffyn, one of two surviving pilots of the original Wright Brothers Exhibition Team and now of Hiller Helicopters, became a most surprised star on the NBC television show, "This Is Your Life," on March 4.

Selected more than a month in advance of the program by Ralph Edwards, genial host and master of ceremonies of this top rated show, Coffyn was completely unaware of all preparations until he was called onto the stage from the audience.

"This Is Your Life" has the unusual format of delving into the past of the secretly gathered life, rounding up teachers and all of them in a reunion on the stage of millions of country.

All this is out the "stage" what is in show. (Continued)



COFFYN ON TV—Picture sequence at left was taken off a television screen during Frank Coffyn's appearance March 4 on This Is Your Life. Top to bottom, they show: Coffyn in audience just after learning he was the subject; father greets son he hasn't seen for years; Admiral Bellinger enjoys seeing old-time friend; and gathered around Coffyn at show's close are (l. to r.) "Strangler" Lewis, Ralph Edwards, Kingsland Coffyn, Admiral Bellinger, "Tiny" Brodwick, Mrs. Coffyn, and Harold Hermes.

Full-Scale Production Assures Quick Delivery of Lower Priced, Completely-Equipped Hiller 12-B

PALO ALTO, CALIF.—Production of the Hiller 12-B helicopter at a greatly reduced price, effective March 1, has been announced by A. W. B. Vincent, Vice President, Commercial Division.

With military production requirements now fulfilled on schedule, this new program represents Hiller's first large scale commercial helicopter production undertaken since the outbreak of the Korean War, and will both parallel and complement the company's long-range military programs.

The Hiller 12-B, similar to the H-23B model currently being delivered to the U. S. Army, will be

(Continued on Page 4, Col. 1)



COFFYN ON TV—Picture sequence at left was taken off a television screen during Frank Coffyn's appearance March 4 on This Is Your Life. Top to bottom, they show: Coffyn in audience just after learning he was the subject; father greets son he hasn't seen for years; Admiral P. N. L. Bellinger enjoys seeing old-time friend; and gathered around Coffyn at show's close are (l. to r.) "Strangler" Lewis, Ralph Edwards, Kingsland Coffyn, Admiral Bellinger, "Tiny" Brodwick, Mrs. Coffyn, and Harold Hermes.

Coffyn and Hermes became good friends.

When Frank Coffyn was honored on the *This is Your Life* television show hosted by Ralph Edwards, Hermes was one of the guests to surprise Mr. Coffyn.

This live show aired on March 4, 1953, three weeks before Richard Hermes, his son and this author, was born.

Hermes was the co-pilot on a flight that is believed to be the one that is now recognized to be Orville Wright's last airplane flight. It occurred on a demonstration flight of the C-69 Constellation on June 5, 1944 at Wright Field, Ohio. The Constellation C-69 was being reviewed by the Army Air Forces as a long-range transport aircraft.

It is reported that during the flight, "Wright was allowed to control the aircraft momentarily during the flight. He even commented that the wingspan was greater than that of his first flight."

According to the June 5, 1944 flight logs of Hermes, the pilot was Brig. General Ernest K. Warburton (then Colonel), Chief of the Air Material Command Flight Test Section. Hermes was the co-pilot for this one hour and 40 minute flight.

Interestingly, this C-69 Constellation was on a return trip to California after setting a transcontinental speed record of 6 hours and 57 minutes (c. 2,300 miles at an average 330.9 mph) and was piloted by billionaire Howard Hughes (and TWA president Jack Fry). Hughes (owner of TWA and a key figure in the development of the C-69 Constellation) brought along Hollywood star Ava Gardner, his girlfriend at the time, to help publicize the new plane's capabilities.

Frank Coffyn signed this "Short Snorter" (on reverse) and likely had a hand in organizing this gathering.



DATE		FLIGHT		REMARKS	CLASSIFICATION	AIRCRAFT MAKE AND MODEL	AIRCRAFT CERTIFICATE MARK	DURATION OF FLIGHT	SINGLE EFF. DAY
MONTH	DAY	FROM	TO						DUAL
MAY	11	WRIGHT FLD	LOCAL			YR-4		30	
	12					XR-6		110	
	12					YR-4		35	
	12					YR-4		25	
	12					XR-6		30	
	12					XR-6		20	
	12					YR-4		100	
	13					YR-4		30	
	13					B-25		40	
	15					YR-4		130	
	15	WRIGHT	LA GUARDIA			C-69		3 45	
	17	NEW YORK CITY	WRIGHT FLD.			C-69		4 50	
	19					XR-5		1 00	
	19	WRIGHT	PATTERSON			B-17		15	
JUNE	1	WRIGHT FIELD	OKLAHOMA CITY			LOCKHEED F-5		3 45	
	3	WRIGHT FLD.	LOCAL	"CONSTELLATION" ORVILLE WRIGHT COL. WARBURTON P+E		SIKORSKY YR-5		30	
	5					LOCKHEED C-69		1 40	
	6					SIKORSKY YR-9		15	
TOTAL									

Herding the **HELICOPTER** *The Best Pilot Tells How to Fly It*

**LIEUT. HAROLD H. HERMES,
AIR TECHNICAL SERVICE COMMAND**

no particular note of vibration, except probably I'd feel out of place in a vibrationless helicopter.

Vibration may be conquered in the future. Even now it is a laboratory research priority. But, in any case, the helicopter is a strange and interesting aerial horse.

Let's examine the controls of the R-4B, a two-place helicopter manufactured for the Army Air Forces by Sikorsky Aircraft. One of the lighter helicopters, it represents the general type being touted by the enthusiastic for immediate post-war commercial acceptance.

Its cabin interior looks almost like the conventional light airplane cabin—two standard seats, dual sticks in the ordinary places, rudder pedals of conventional design. But there are differences.

Low between the seats is the main rotor pitch control lever and throttle by which the pilot governs ascent and descent through manipulation of the angle of incidence or pitch of the main rotor blades. Higher is the clutch and rotor brake control lever by which the pilot engages and disengages the main rotor. Just above the instrument panel is the main rotor pitch indicator and in the panel's center is the dual engine and rotor tachometer.

The helicopter's ability to fly comes from the lift resulting from the movement of airfoils, the rotor blades, through the air. In the take-off or in hovering, when the main rotor is turning parallel to the ground, increased pitch, by allowing the whirling blades to bite into more air, causes the helicopter to rise. Decreasing the pitch allows it to settle. Pitch change is a function of the main rotor pitch control lever, to which the throttle is partially synchronized.

For forward, backward and sideward flight, the helicopter pilot uses the stick to tilt a swash plate, causing the incidence of each main rotor blade to be highest at one point in the rotational circle and lowest at 180 degrees from that point. This action, known as cyclic pitch change, tilts the main rotor disk and causes the helicopter to move in the direction of the tilt. Helicopter stick control is quite sensitive.

Thus, when the helicopter has appreciable forward speed, the stick is equivalent to the conventional airplane stick. Increasing the pitch of the main rotor, with attendant synchronous opening of the throttle, is equivalent to opening the throttle in a conventional plane.

Coordinated turns generally are made by a conventional movement of the stick. Because the craft has great directional stability, this maneuver may be made without rudder. Sharper, skidding turns may be made with the rudder.

The tail rotor's main function is to compensate for main rotor torque, but it also provides directional control. Such control is achieved by manipulating the rudder pedals as in a fixed-wing airplane. The controls increase or decrease the incidence of the tail rotor blades simultaneously.

Because main rotor torque varies with each change of power, rudder pedals must be manipulated for each flight condition. Flying forward at maximum pitch and power, left rudder may be required; in normal power flight, the pedals will be about neutral; in a power-off glide, right rudder will be needed. In a take-off, the increased main rotor torque will tend to turn the helicopter to the right and reduction of pitch and torque during landing will tend to turn it to the left.



The author.

Before trying flight technique, it is well to understand four things: translational lift, ground cushion, autorotation and the fact that controls absorb power.

Because of what is known as translational lift, up to a certain speed the faster a helicopter moves the more lift it will have. The greatest amount of power is necessary for calm-air vertical takeoff and hovering. Less power is required to maintain level flight forward because the main rotor then is covering a greater area of air which requires less downward acceleration for the same lift. Minimum flying power requirements are reached at 40 to 50 miles an hour, at which speed the power absorbed by the drag of the main rotor begins to exceed that absorbed by the downward acceleration of the air.

Translational lift for take-offs may be obtained in measure by heading into the wind, which may allow the craft to take off with an over-load which would hold it on the ground on calmer days. Helicopter pilots use translational lift by beginning forward flight immediately after an overload take-off.

(Continued on page 8)

DECEMBER, 1944

5

In 1944, a lot of people wanted to know about the new "flying corkscrews" as helicopters were sometimes called. Hal wrote an article for *Air Pilot and Technician*, which was published in December 1944. Its cover price was "35 cents."

Epic Rescue by Captain Frank W. Peterson

On January 17, 1945, after receiving urgent radio orders from General Henry "Hap" Arnold, Wright Field crews began disassemble this helicopter at 8pm. By 6am the next morning, it was ready to be loaded onto a C-54 transport plane.

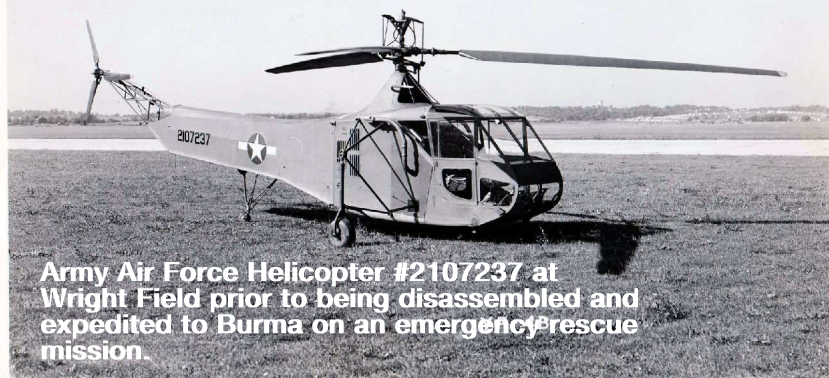

Army Air Force Helicopter #2107237 at Wright Field prior to being disassembled and expedited to Burma on an emergency rescue mission.



The total elapsed time from Wright Field to Burma was 74 hours 35 minutes. Actual flying time was 53 hours 10 minutes.

Hal Hermes and Frank Peterson were lifelong friends. They were in the same class throughout their entire pilots training and then both became Wright Field test pilots. After the war, their paths crossed frequently both personally and professionally. Frank, or Pete, as his friends called him, became chief test pilot with Hiller Aircraft and the two flew together often. On right, a marriage photo of Frank W. Peterson.

After this highly accelerated trip around the world, by 9am on January 25, Capt. Peterson and his crew had the helicopter reassembled and Peterson headed alone to Sinkaling, a makeshift strip approximately 120 miles away. The helicopter had no radio and Peterson was unfamiliar with the country. It took three attempts to top one 5,000-foot peak, which drained the fuel tank. Peterson landed it on a sandbank on the Chindwin River until two 5-gal. fuel cans were air dropped.

After landing at Sinkaling, Captain Peterson had a coffee, refueled, and took off alone for the final rescue of Pvt. Howard Ross, who had been shot in the hand. He made it way to a weather station about an hour away, but because there was considerable turbulence, the helicopter had run short of gasoline and forced Peterson to spend the night waiting for another fuel drop the next morning.

Spotter planes noticed that Captain Peterson did not take off at once. Several Nagas tribe members helped Peterson secure some white cloth with which Peterson spelled out "OIL" which was later air dropped.

After loading Pvt. Ross into the helicopter, Peterson discovered that the helicopter would not lift off the ground at this altitude with this heavier load. They turned the helicopter so that it could get a "running start" by pointing it downhill to gain speed for the eventual climb.

Captain Peterson was only 21 years old at the time. This is noted as one of the earliest helicopter rescues completed - and perhaps, in terms of distance, the longest ever.

For more information about this rescue:
<http://www.helis.com/stories/burma45.php>



The Man Who Rode Whirlwinds

Five months after the surrender of the Japanese and the end of WW2, Captain Hermes (with the additional designation of "Army Chief Test Pilot on Helicopters") was given an honorable discharge on February 10, 1946, the day before his 26th birthday.



After the war, Hermes continued as a test pilot and flight safety engineer with the CAA (Civil Aeronautics Administration), which was renamed to the Federal Aviation Agency (FAA) in 1958.

His first assignment at the CAA was the testing of the Sikorsky S-51. Hermes must have been pleased to once again be flying with his good friends at the Sikorsky Factor in Connecticut. The S-51 received its CAA type certification on April 17, 1947. Around this time, Igor Sikorsky sent Hermes an autographed photograph of the S-51 shot during its maiden flight on Feb. 16, 1946.

April 1949. Hal Hermes is piloting a Kaman K-190, the world's first commercial twin-rotor helicopter, at Bradley Field, Connecticut. Behind him is his boss, Roy Clark.



Hermes was the CAA test pilot for the Kaman K-190 and K-225 helicopters, which used a unique twin-rotor system and Kaman-patented servo-controls.

These helicopters also had no tail-rotors because of the contra-rotating intermeshing rotors. The Kaman K-225 was the first gas turbine-powered helicopter and an early model of this helicopter resides in the Smithsonian Institution National Air and Space Museum.

Considering that Kaman's company was only four years old, these radically different helicopters were an amazing technological achievement. 26-year old Charles Kaman started Kaman Aircraft in 1945 working first out of his mother's garage. Today in 2015, Kaman Aerospace is a major company with annual sales approaching \$2 billion.

April 1949. Charles Kaman (far right) receives type certifications for Kaman's first helicopters from Roy Clark, CAA senior inspector, with Harold Hermes (test pilot) behind.

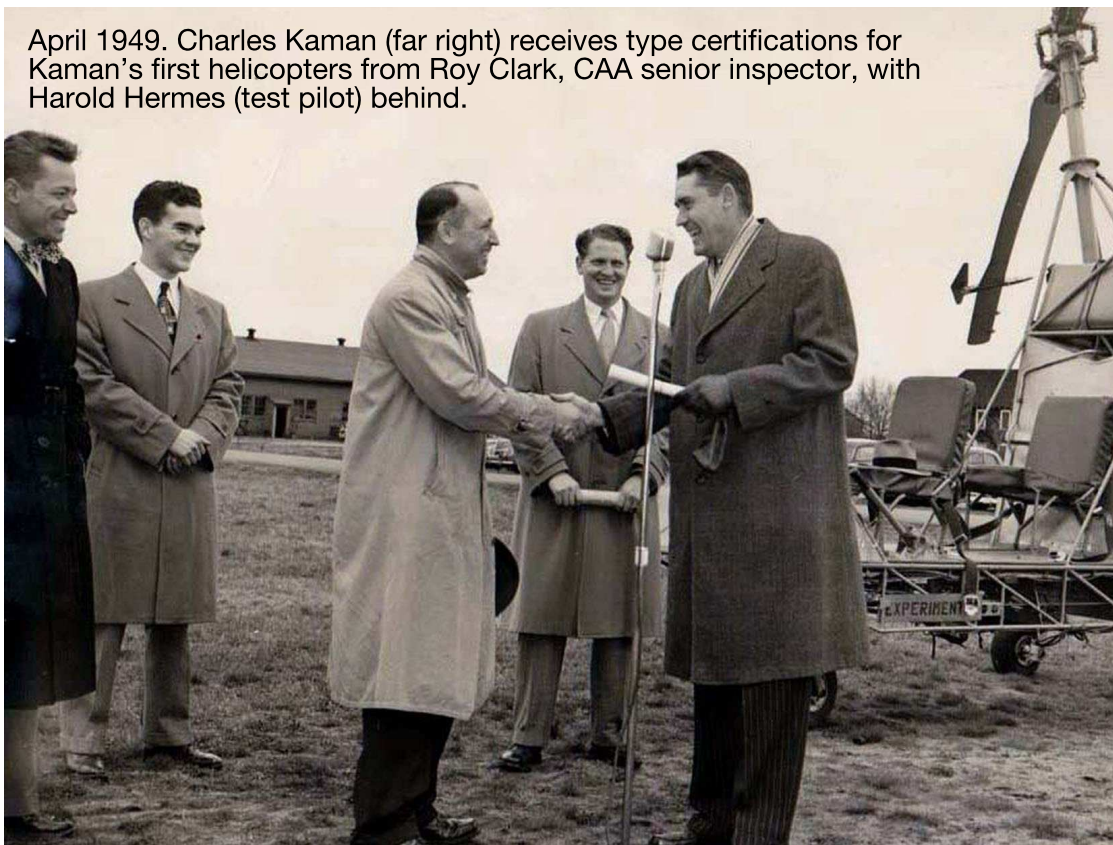

Kaman was an early innovator constructing laminated wood rotor blades, which in time led to a spin-off company, the Ovation Guitar Company, which used their unique expertise with wood laminates to make the world famous "Ovation" guitar.

The Man Who Rode Whirlwinds

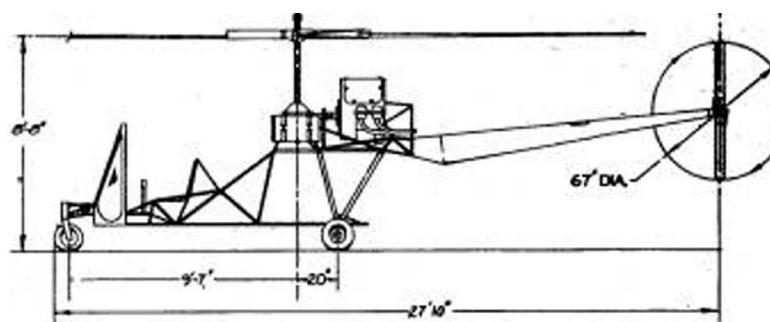

Diagram of Seibel S-4

Hermes first met Charles M. Seibel while Seibel was developing the S-4A, which Hermes tested in October 1950.

The Man Who Rode Whirlwinds



Seibel partnered with Cessna and the S-4B would serve as the basis for the design of the famous Cessna CH-1 Skyhook (photo left).

The CH-1 Skyhook set a number of records and "firsts" including an altitude world record, first helicopter to land on Pike's Peak, and the distinction of being the first civil certification of a helicopter to be operated under the Instrument Flight Rules (IFR).

That landmark IFR certification for the Skyhook evolved from a long-term collaboration between Hermes and Seibel. Together they published an important technical paper: IAS Paper No. 61-53 by Harold Hermes and Charlie Seibel. It was presented at the *Institute of the Aerospace Sciences* 29th Annual Meeting.

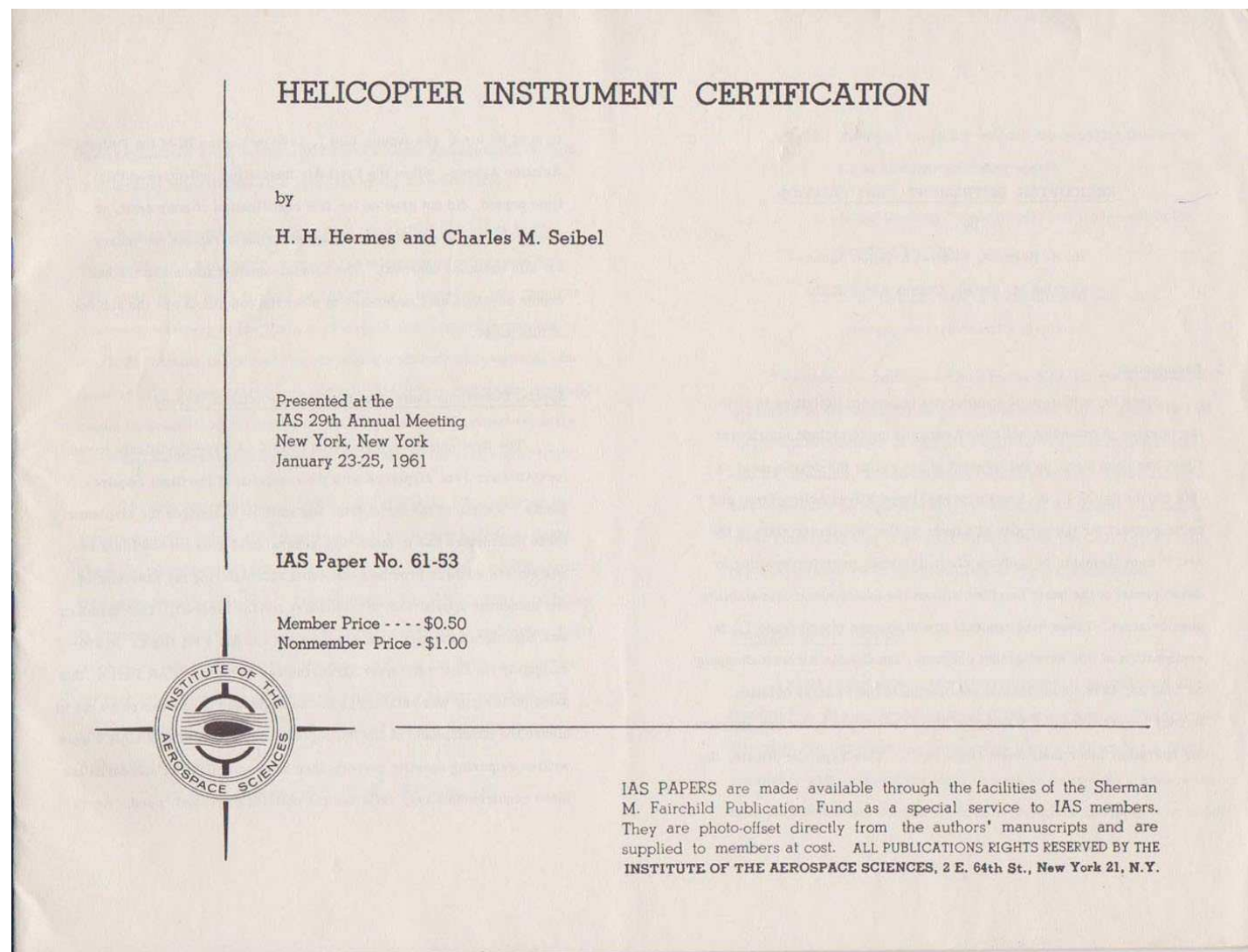

The Man Who Rode Whirlwinds



Lila Hampton was working at the CAA administration office at Tinker Air Force Base in Oklahoma City, Oklahoma. Above photo taken after a plane ride circa 1949.

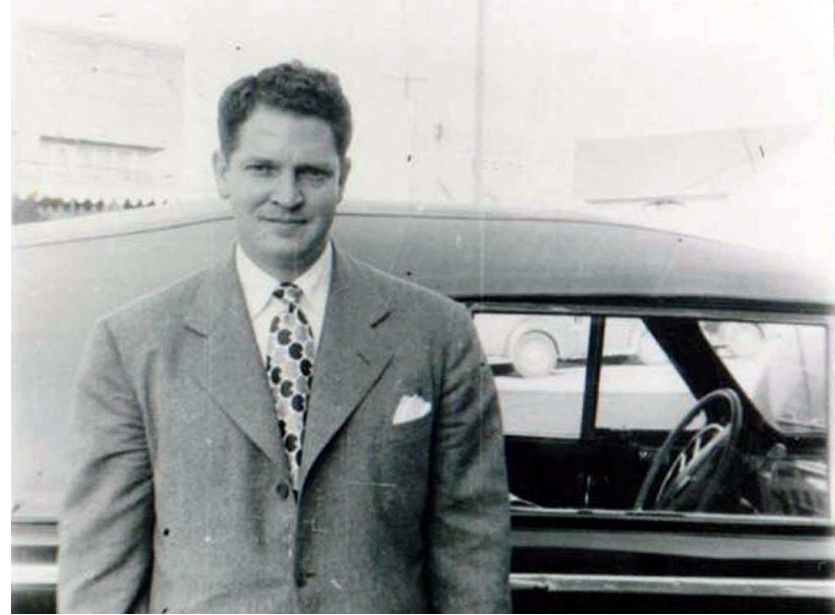

Soon after WW2, Hal purchased himself a dark green Chrysler convertible.



Hal Hermes met Lila at Tinker Air Force Base in late 1949. Hal flew frequently into Tinker AFB on business. After a six month whirlwind romance, they were married in Oklahoma City on June 17, 1950.



Lila Hampton's wedding photo.

Hal and Lila Hermes had three children: Diana (1951), Richard (1953) and Nancy (1954). Hal always kept in touch with his good friend Frank Peterson, who moved to Palo Alto, California to work with Hiller Aircraft.

It was a fertile period for helicopter technology as the science of vertical flight evolved. In the 1940's, the control systems of a helicopter were rudimentary and inherently dangerous. But with ingenious inventors spread across America and the money, research and political will of the US military, the helicopter was evolving rapidly.



Frank Peterson piloting "hands off" in a demonstration of a Hiller prototype. The other man was pushing on the wheel full strength to try and unbalance the helicopter.

This Hiller NC-5 helicopter used the Hiller-patented servo-paddle method of cyclic control, also called the Hiller "Rotomatic Control".



Hal Hermes with Sikorsky team (circa 1950) that worked on the certification of the Sikorsky S-55, called the "H-19 Chickasaw" by US Army, which has a tradition of naming helicopters with the proper name of an Indian tribe.

The H-19 Chickasaw was the US Army's first true transport helicopter. It played an important role in the initial formulation of Army doctrine regarding air mobility and the battlefield employment of troop-carrying helicopters.

The Man Who Rode Whirlwinds

McCulloch MC-4

Hermes flew this stylish helicopter (Reg#N4070K) five times between Oct. 20 and Oct. 24, 1952.

Made by McCulloch Motors, which made target drones during WW2 and is now known for their chainsaws.

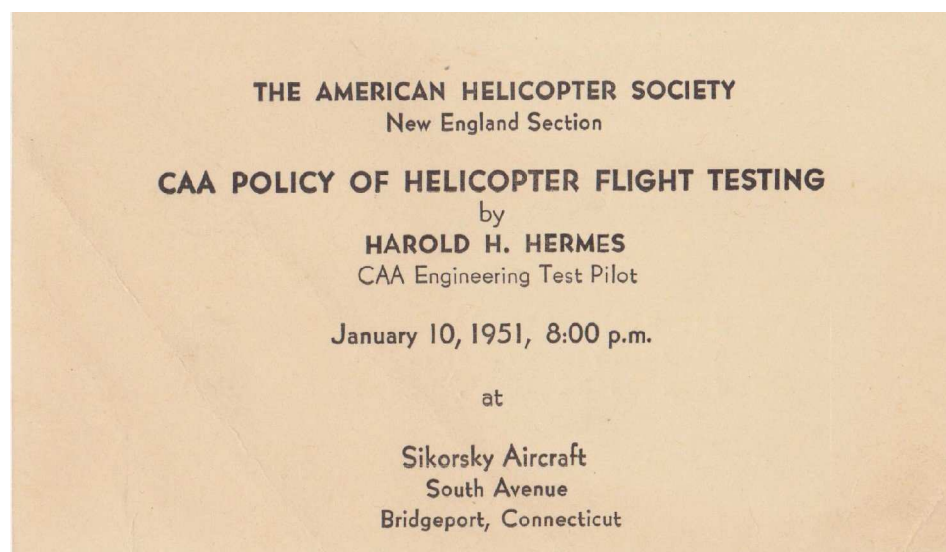

Hal Hermes at White Sands Missile Range
(New Mexico)

December 1961



Throughout most of his career, Hermes had hands-on experience with most models of helicopters flying in America, but it should be known that Hermes logged many hours testing a wide range of fixed-wing aircraft.

His pilots license read, "ALL RATINGS AUTHORIZED" meaning that he was authorized to fly any type of aircraft, commercial or military. Hermes' flight log list hundreds of different aircraft including gliders, light aircraft, seaplanes, float planes, fighters, jet fighters, as well as jet and propeller versions of long-range commercial and military transports and heavy bombers. Hermes had significant flight testing responsible for the following heavy bombers and long-range transports.

Boeing B-17 Flying Fortress
Boeing C-97 Straofreightor
Boeing B-307 Sratoliner
Boeing B-50 Superfortress
Douglas C-124 Globemaster II
Douglas DC-4
Douglas DC-3
Douglas A-26 Invader
Consolidated B-24 Liberator
Fairchild C-82
Lockheed C-69 Constellation



The Man Who Rode Whirlwinds

Hal also had extensive flight testing experience with light aircraft including "most Piper, Cessna, Beech, Fairchild models."

Beechcraft C-45 Expeditor
Beechcraft B-55
Bell P-39 Airacobra
Cessna C-310
Corvair CV-580
Curtis C-46 Commando
Curtis P-36 Hawk
Curtis P-40 Warhawk
Lockheed P-80 Shooting Star
Martin M-202
North American P-51 Mustang
Piper PA-30 Twin Comanche
Piper PA-23 Apache



There were some rather unconventional planes in this era. Above is the Goodyear "Rubber Fighter" sent to Hal Hermes by Dick Ulm in 1957, who on the back writes:

*"Also called an "Inflat-O-Plane"
500# Gross Weight
44HP Nelson Engine
First Flight Jan 10, 1957"*

In separate note, Dick Ulm says he has "over 60 flights" ...and that:

"at 4000 ft. in this you feel real bold."

No other information could be found on the internet about this unusual aircraft.

The Life of a Test Pilot

Over his career, Hermes logged 6,537 flying hours.

There are many pilots who can boast more flying hours than Hal, but few can match the sheer number of challenging and dangerous flight situations that Hermes strapped-in for throughout his flying career. Being a Wright Field test pilot during WW2 demanded a special mind set and skill set that only a few know, but many others just call it the “Wright Stuff”.

It should be noted that Hermes' test flights were typically less than an hour. His log book is full of intentional “dives”; “stalls”; “power-off landings”; “stickless landings”; “water landings”; “night water landings”; and ongoing testing and retesting of every new engine, rotor, component and innovation often purposely scheduled during weather extremes.

Below is a sample page from his flight log book after his war service while at the CAA. It illustrates the schizophrenic schedule of a “Flight Engineer Inspector”.

1946			MODEL	CERTIFICATE MARK	FLIGHT	DUAL	PILOT
APRIL	18	BUSH FLD. LOCAL	CARBON DIOXIDE TEST AND A/S C.K.	NOORDUYNE C-64	AF-330	1.20	1.20
	18		COOLING TESTS C.A.H.R.	STINSON AT-19	FK 840	1.30	1.30
	19		T.O. AND LANDING TESTS	AT-19	FK 840	1.00	1.00
	19		FLIGHT CHARACTERISTICS	STINSON L-5	AF 8975	1.00	1.00
	19		CHECK OUT AND STABILITY	SIKORSKY OS2U-1	NAYY	.45	.45
	22	BUSH FIELD LOCAL	POWER OFF STALLS, SINGLE ENGINE	CURTISS C-46D		1.00	
	22		SINGLE ENGINE INSP. HEIMERINGER	C-46D		1.00	
APRIL	22		ATTEMPTED A/S CAL. INSP. LATHROP	NOORDUYNE C-64	AF 330	.20	.20
	23	BUSH FIELD WASH. D.C.	H. DOYLE C.A.A.	DOUGLAS C-41	AF 0070	3.00	
	24	WASH. DC NY	GORANSON C.A.A. NC-42	BEECHCRAFT C-43	NC-42	2.00	2.00
	24	N.Y.C. (LAGUARDIA) BRIDGEPORT	INSP. O'BRIEN AND LOCAL	C-43	NC-42	1.00	1.00
	25	BRIDGEPORT, CONN. LOCAL	A/S CAL., VIVNER (NEW BLADES)	SIKORSKY S-51	NX-92800	1.00	1.00
	25	BRIDGEPORT, CONN. LOCAL	FLIGHT CHARACTERISTICS, HOVERING	S-51		1.10	1.10
	25		POWER OFF LANDINGS (5)	S-51		.30	.30
	26		MAX. POWER OFF ROTOR RPM 262	SIKORSKY S-51	NX-92800	.30	.30
	29		LANDINGS AND TAKE OFF'S	S-51		1.00	1.00
	29		POWER CAL. @ 2300, 2200, 2000 RPM'S	S-51		.30	.30
	30		2-CHECK CLIMB GW 4985# 10,000 FT	S-51		2.00	2.00
PILOT: <i>Harold H. Hermes</i> ATTESTED BY: <i>Flight Engr. Inspector</i>					TOTAL	154.9	110

And for all the risks of performance flight testing of new aircraft, Hal Hermes had a superb safety record.

He walked away from all three of his known crashes:

In March 1944 in a B-17G (the final version of the “Flying Fortress”) near Cheyenne, Wyoming.

In Nov. 1944, while flying a Sikorsky XR-5 helicopter crash near Barksdale Field, Louisiana.

In June 1952, a helicopter crash (probably a Bell 47B), when a fire destroyed the entire craft near Lockport, Illinois (photo on the right).



HELICOPTER BURNS—Shown is the wreckage of the Lewis college helicopter, after fire destroyed it yesterday. Al Luke, pilot, and a Chicago CAA official escaped without a scratch.



Upon Hal Hermes' retirement from the FAA in 1976, his fellow test pilots honored him by collaborating with elders of the local Oklahoma Otoe aboriginal tribe to officially grant Hal Hermes the name of:

WA-SHE-GA GOT-DAH DA-NA-KE

which in the Otoe language means, "Man Who Flies Whirlwind"

"The Otoe Tribe in Oklahoma hold integrity and personal honor high on the scale of living."



American Defense Service Medal
Good Conduct Medal
WW II Victory Medal
American Theatre Ribbon

Air Force Commendation Medal in 1971 for his service in the Air Force Reserve
Award for Superior Accomplishment, Dept. of Commerce, 1952

FAA Special Achievement Awards (1966 and 1970) for contribution to "airworthiness standards for light aircraft" as well as for Hermes' work with Charles Seibel on the FAA Instrument Flight Rules for the Helicopter.

The Man Who Rode Whirlwinds



For all the grit and grease expected of a Wright Field test pilot, Hal Hermes rarely brought any of that into his home and personal life. Family and friends remember him as a calm, patient, soft-spoken, unassuming man, who loved and cared well for his family. Hermes was an active member of the First Christian Church where he served as a Deacon and an Elder. No one can recall a single incident of him cursing or speaking ill of another person.

Hal regretted never having finishing his engineering studies but he adopted an uncommon drive to be well informed in his craft. He studied aviation science and electronics throughout his life. He had excellent mental math skills and could make a slide rule fly.



Ret. Lieutenant Colonel U.S.A.F Harold "Hal" or "Red" Hermes passed away on July 31, 1989. He was survived by his wife, Lila H. Hermes; daughters, Nancy K. Hermes and Diana L. Hermes, and his son, Richard H. Hermes.

He is buried at Chapel Hill Memorial Gardens in Oklahoma City.

Hal Hermes was a Founding Member of Twirly Birds; a proud member of the Quiet Birdmen; Life Member of the Order of Daedalions; Life Member of Retired Officers Association; Life Member Reserve Officers Association; member American Helicopter Association; member Helicopter Association International; and a Life Member of the Air Force Association.



Photo below: Lieutenant Colonel Hal Hermes was award the Meritorious Service Medal by the U.S. Air Force Reserve in 1971.

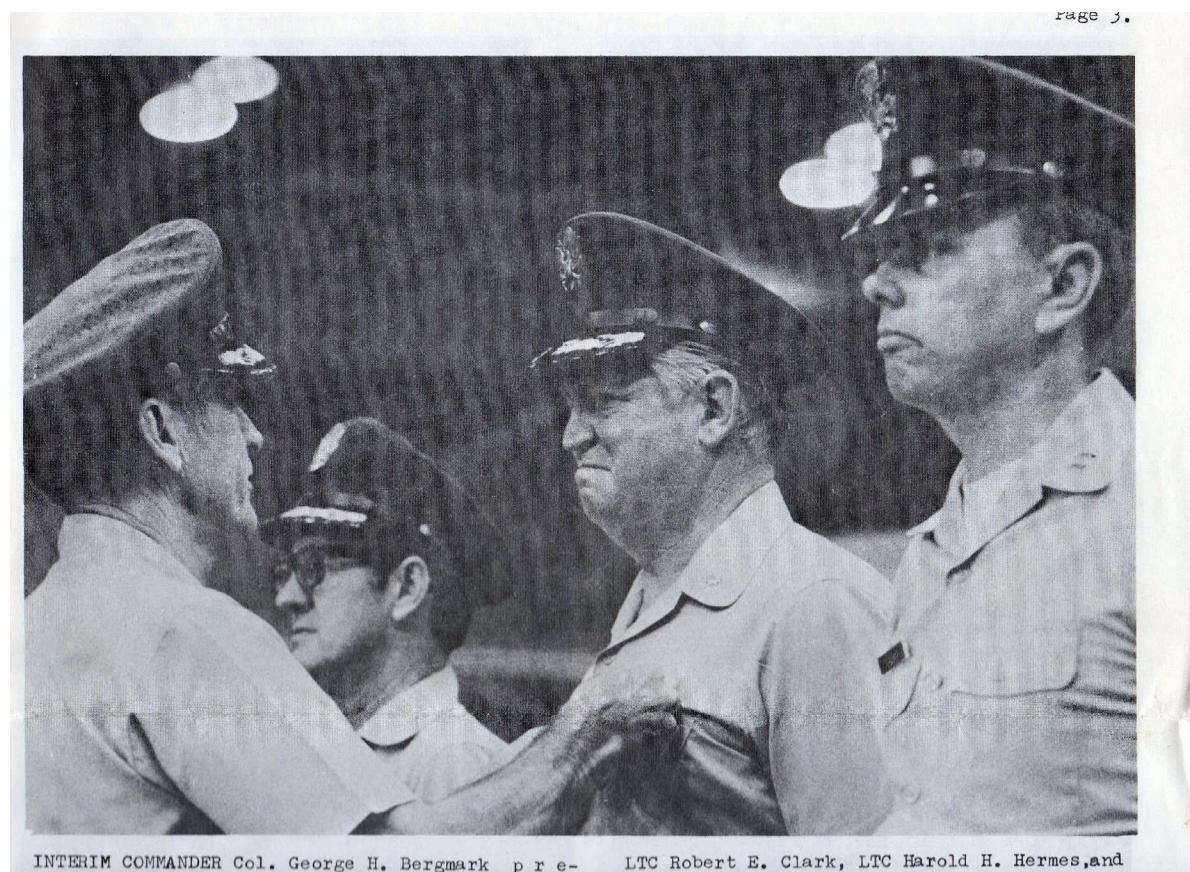

The Man Who Rode Whirlwinds



The Man Who Rode Whirlwinds

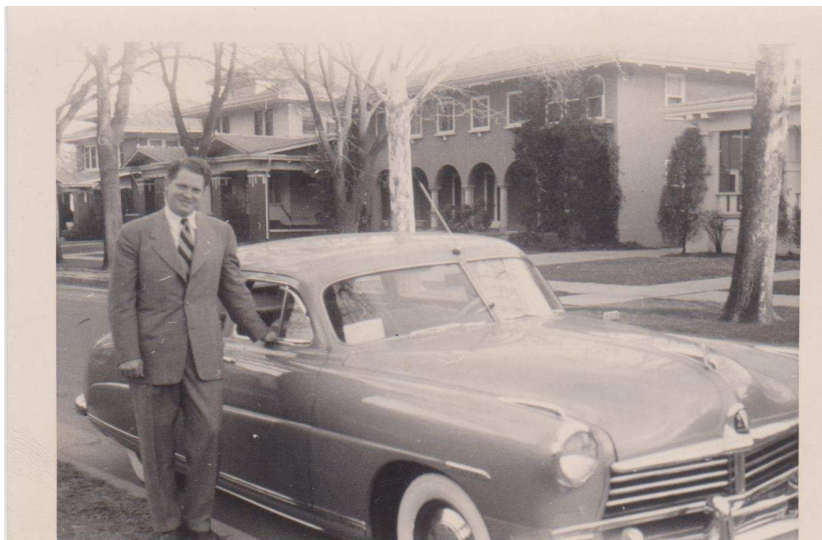

The Man Who Rode Whirlwinds

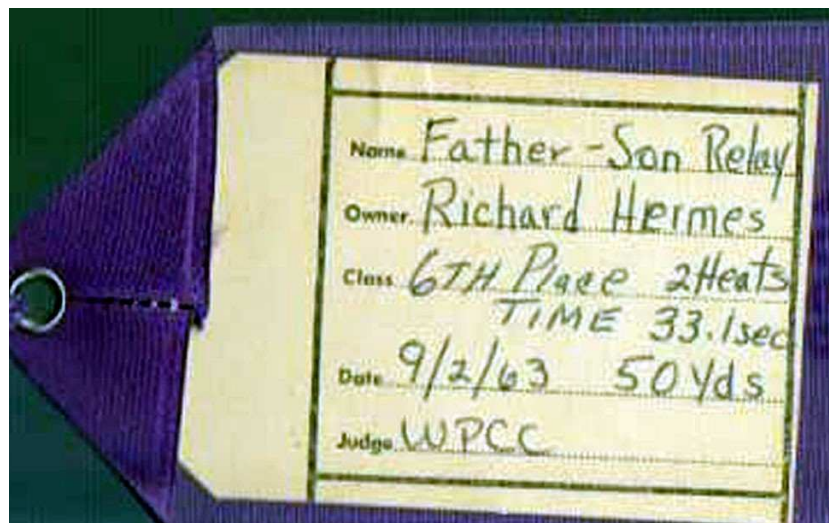
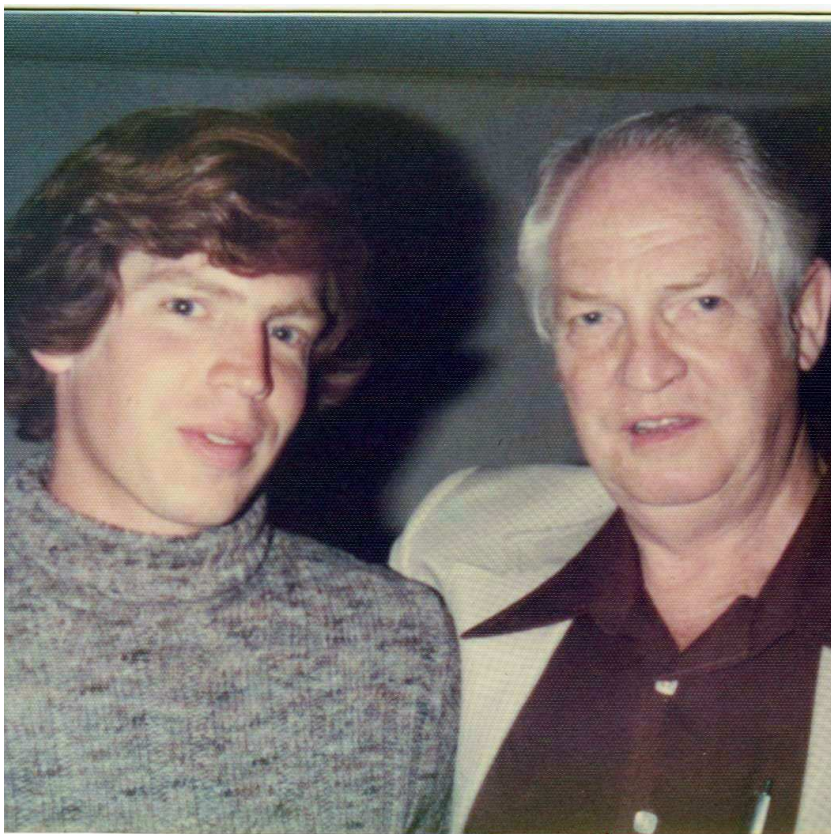

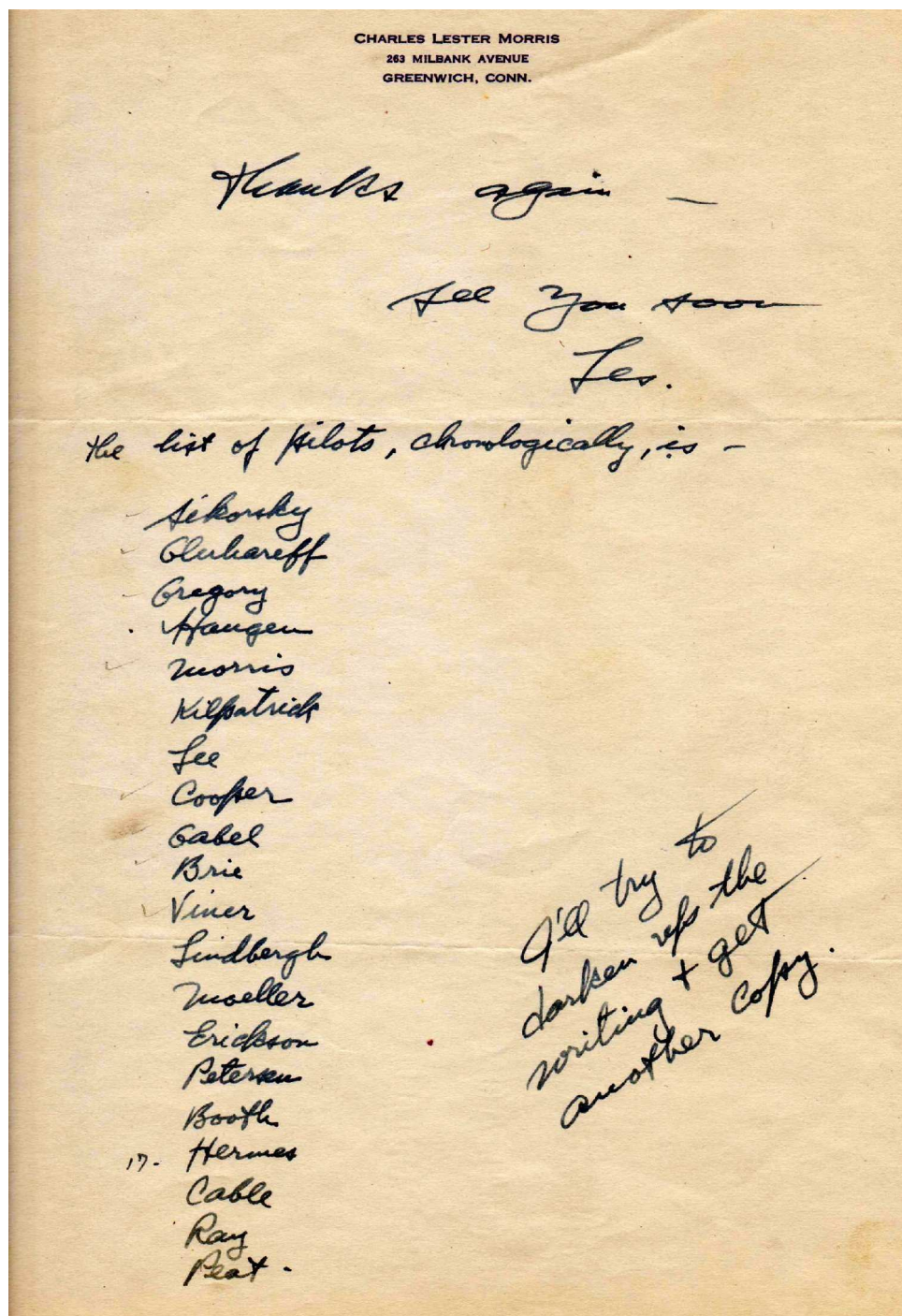

Letter to Hal Hermes from C. L. "Les" Morris (Chief test pilot at Sikorsky Helicopters) with his list of pilots in order of their solo date in a helicopter.



Hal Hermes' older sister Frances also served as a WAC in the USAAF. Before the war, the Hermes family had moved to Oklahoma City. The above article notes that Hal Hermes **"was one of the officers who flew the first helicopters in Oklahoma City"** in October 1944.

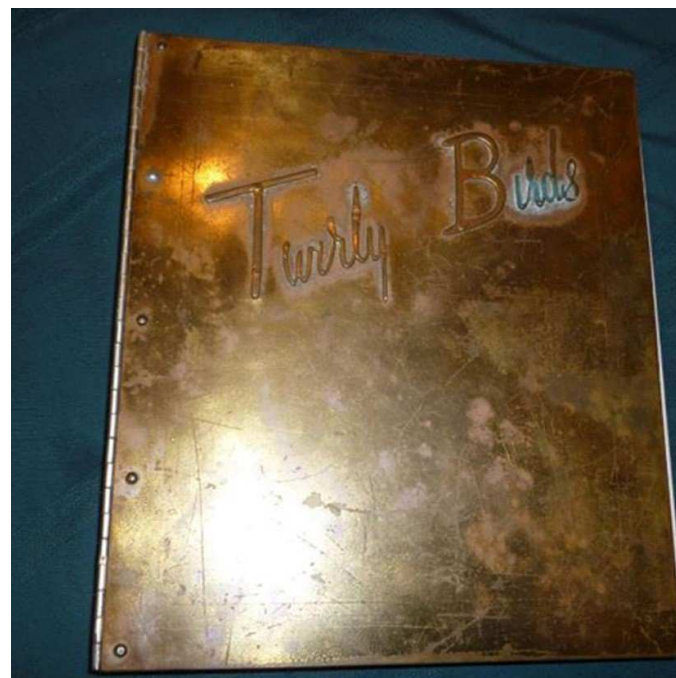

Twirly Birds is "an exclusive and elite International Organization of the pioneering pilots of helicopters and other vertical take-off aircraft founded in 1945."

Harold "Hal" Hermes is a Founder Member, an honor reserved for those pilots who soloed a helicopter or other vertical take-off aircraft in sustained complete flight, including a take-off and landing prior to V-J Day (14 August 1945).

Until May 21, 2015, the Twirly Birds did not have a website profile of Hal Hermes among the other Founding Members. Now, the profile of Harold "Hal" Hermes can be found at: <http://www.twirlybirds.org/history2.html>

In addition, the Coordinator for Special Collections at The University of Texas at Dallas McDermott Library, Special Collections and Archives Division in Richardson, Texas has agreed to enter ***The Man Who Rode Whirlwinds*** permanently into the "fabled" **Twirly Birds Brass Book**.

The Brass Book's front and back covers are made from sheets of brass. Including the multiple pages of pictures and resumes, it weighs 13 pounds. It contains the biographies of those "Twirly Birds who have pulled pitch for the last time."



The Man Who Rode Whirlwinds

Hal Hermes (circa 1947) with a test model of the Bell 47, one of the most popular helicopters in history.

Throughout his long career with the CAA and FAA, Hermes was instrumental in the testing of all of the many models and variants of the Bell 47. According to his flight log, his last FAA flight was in a Bell 47G-3B2A on October 29, 1975.

The Bell 47 was the first helicopter certified by the CAA/FAA. It entered U.S. military service in late 1946 and was deployed for three decades in a variety of versions and designations. The Bell 47 family has proved to be one of the most versatile and recognizable helicopters in the world. It has become the helicopter of choice for flight instruction in many countries.